

ALUMINIUM STAIR 1700 SERIES

Construction Specifications

Overall stair diameter is 1600mm. Stair opening must be 1700mm x 1700mm circular or square.

Centre Column

114.3 O.D. X 6.35 CHS Grade 6060 - T5 Aluminium.

Landing

6mm aluminium plate (Grade 6060 - T5) is laser cut and folded to create turn-downs for fixing points. Can be attached to timber, concrete or steel.

Treads & Risers

6mm aluminium plate (Grade 6060 - T5) is laser cut and folded with a 100mm turn-down both sides to weld to the riser. Risers are between 190mm - 220mm as determined by floor to floor height. Width of treads free of obstruction is 740mm. Anti slip tread mats are standard and are replaceable.

Stair Handrail

Polymer handrail system is 38 x 5mm round. Aluminium handrail system is 32 x 1.6mm CHS. Balusters are 19 x 1.8mm SHS aluminium with a maximum spacing of 125mm. Newel posts, top and bottom are 50 x 50 x 3mm (SHS Grade 6060 - T5) aluminium. The handrail is provided on one side of the stair with a minimum height above the tread nosing of 865mm.

Balustrade Panels

End posts are 50 x 50 x 3mm (SHS Grade 6060 - T5) aluminium. Top rail is 32 x 3mm (CHS Grade 6060 - T5) aluminium. Bottom rail and in-fills are 19 x 1.8mm (SHS Grade 6060 - T5) aluminium. Balustrade panels are at a minimum height of 1000mm above floor. Balusters are spaced with a maximum gap of 125mm.

Stair Geometry

Stair has risers between 190mm - 220mm with 16 treads to circle at 22.5°. The going measured at 7/10ths of the unobstructed width is a minimum of 210mm. The slope relationship is between 595mm - 660mm. The gap between tread risers does not exceed 125mm.

Headroom

Using a standard landing with a 50mm turn-down, clear headroom must be 2000mm minimum.

Modular / Kit Form

The spiral stair is pre-manufactured and mechanically assembled onsite. No welding, cutting or grinding is required.

This system is covered by Registered Design No's: 157138 & 150823 and may not be manufactured or copied, without the written consent of Spiralworks Pty Ltd.

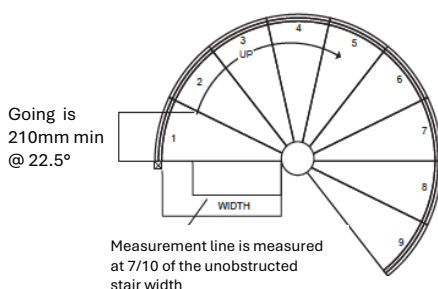
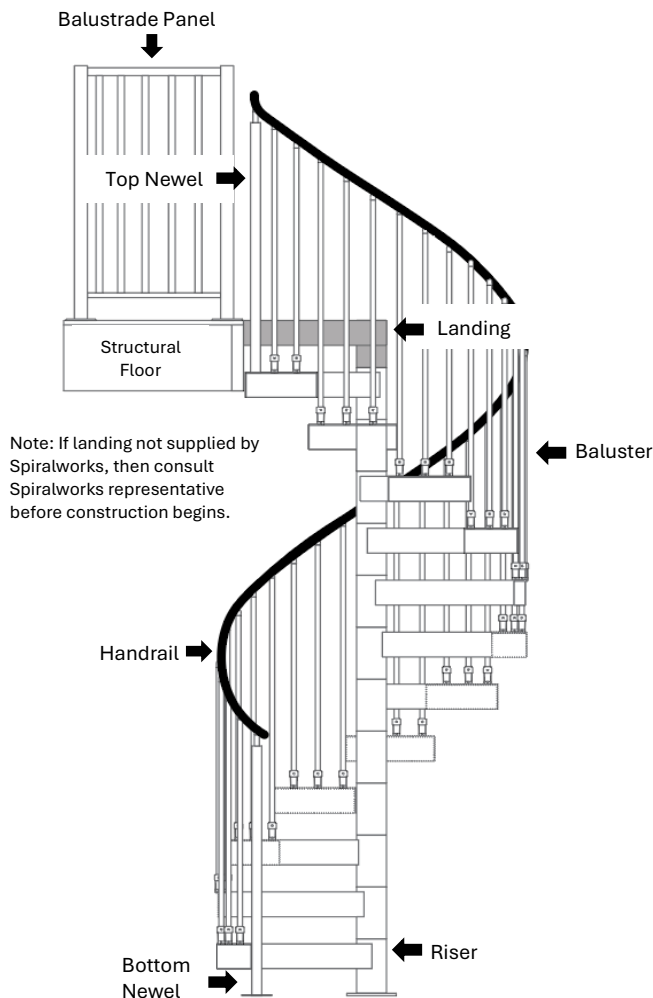

Bottom Newel Post

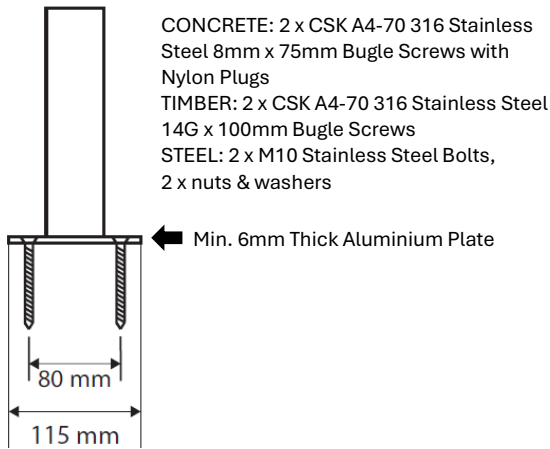

Centre Column Base Plate

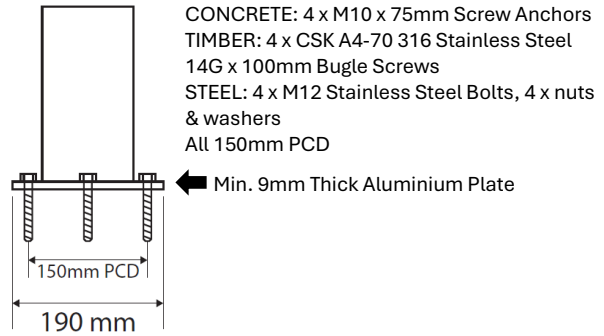

Standard Landing Detail
150mm Turn-Down

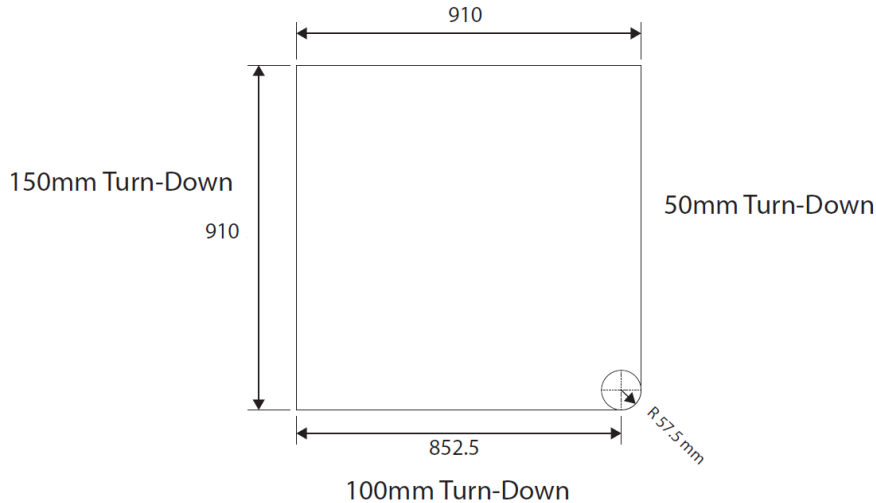

EXAMPLES OF SETOUT - WE BUILD TO SUIT
190mm to 220mm Riser - 16 Treads to Circle at 22.5°
Mid-landing required for 19 or more risers

Floor to Floor Height	2320	2510	2700	2890	3080	3270	3460	3650	3840	4030	4220
Number of Risers	12	13	14	15	16	17	18	19	20	21	22
Number of Treads	11	12	13	14	15	16	17	18	19	20	21
Rotation	247	270	292	315	337	360	382	405	427	450	472

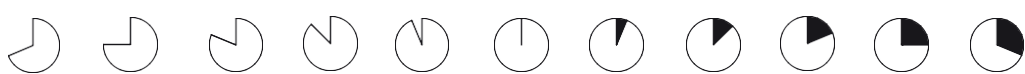

Landing Examples Dotted line denotes fixing face

